

Suction capacity

[dm³/min]

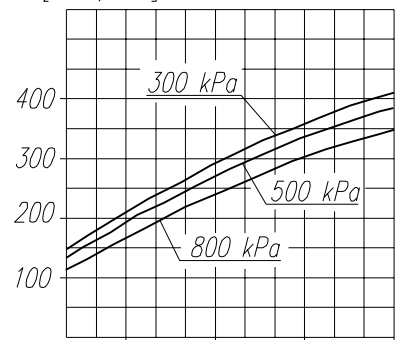

Power consumption

[kW]

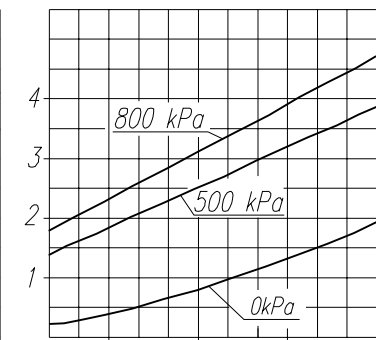

Time to fill a tank of 40dm³ capacity

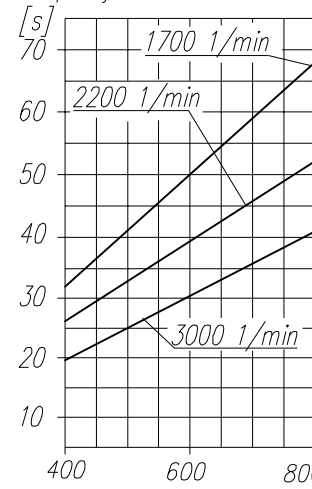

Max. r.p.m. for continuous duty

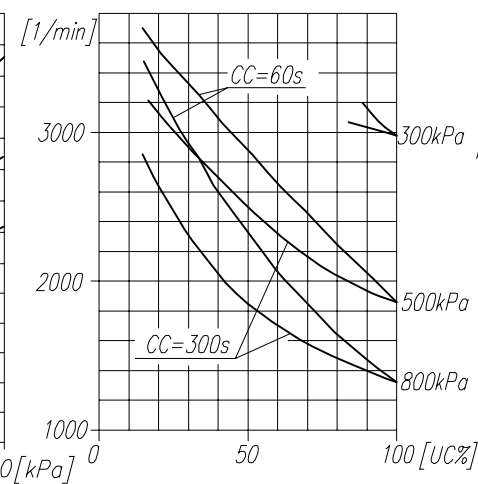

TECHNICAL DATA:

- Number of cylinders - 1
- Cylinder diameter - 90 mm
- Piston stroke - 36 mm
- Total piston displacement - 223 cm³
- Mass - 11.5 kg
- Working pressure - 800 kPa
- Max. pressure for short time duty - 1000 kPa
- Max. allowable temp. of compressed air - +220 °C
- Cooling by inflation of air, with the speed of the stream min. - 4m/s
- Lubrication forced circulation, splash lubrication
- min. pressure of oil - 200 kPa

SYMBOLS DESCRIPTION:

- 0 - suction connection (on the head signifying "S")
 - 2 - discharge connection (on the head signifying "D")
 - 81 - lubricating oil inlet
 - 82 - lubricating oil outlet and crankcase breathing
- Numeral signs according to International Standard ISO-6786
 T - rating plate
 * - max. angular deflection of the compressor

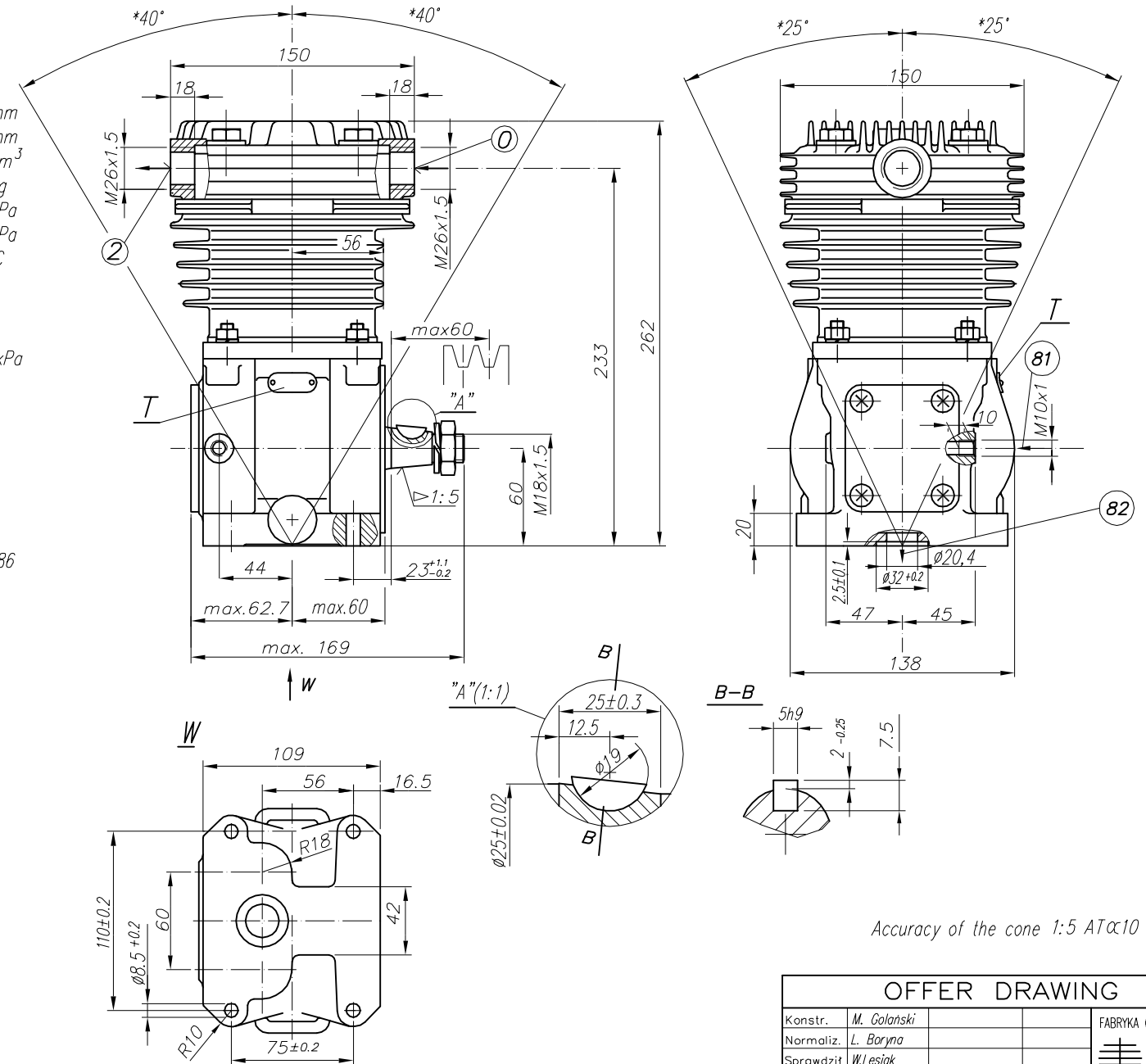

Accuracy of the cone 1:5 ATα10 PN-77/M-02136.

NOTE! The above characteristics are for open-inlet-valve control system at minimum cooling requirements and at ambient temperature +20°C

DEFINITIONS: CC=CT+CL - period of average operating cycle

$UC = \frac{CT}{CC} \times 100\%$ - percent ratio of compressor full load operating time in average operating cycle (also called percent duty cycle)

CL - compressor no-load operating time (exhaust to the atmosphere)

CT - compressor full load operating time

OFFER DRAWING			
Konstr.	M. Golański		FABRYKA OSPRZĘTU SAMOCHODOWEGO
Normaliz.	L. Baryna		POLMO-Łódź S.A.
Sprawdził	W. Lesiak		FOS Stuzba Rozwoju
Zatwierdził	B. Kleto		
Podziałka	Nazwa		
1:1	Compressor 601.07.907		